

2 - ANGLES - a1395
(GR.-A36)

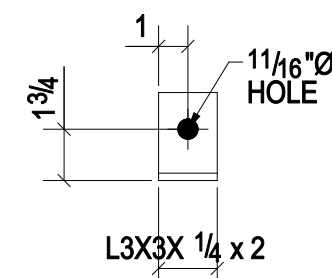

4 - ANGLES - a1475
(GR.-A36)

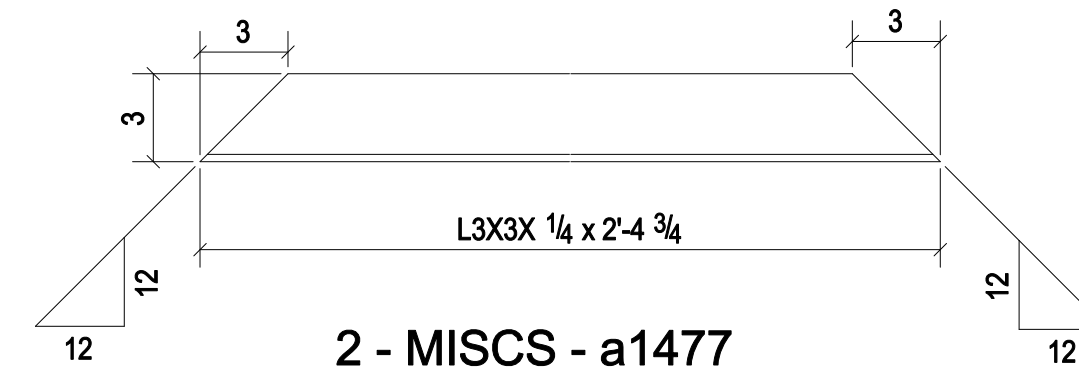

2 - MISCS - a1477
(GR.-A36)

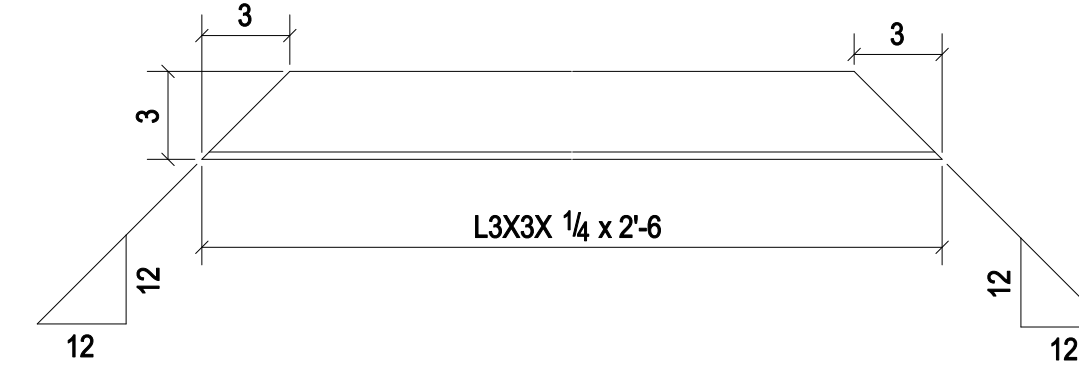

2 - MISCS - a1478
(GR.-A36)

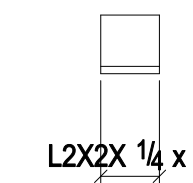

ONE - ANGLE - a1489
(GR.-A36)

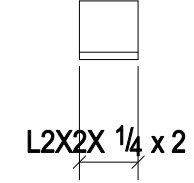

3 - ANGLES - a2292
(GR.-A36)

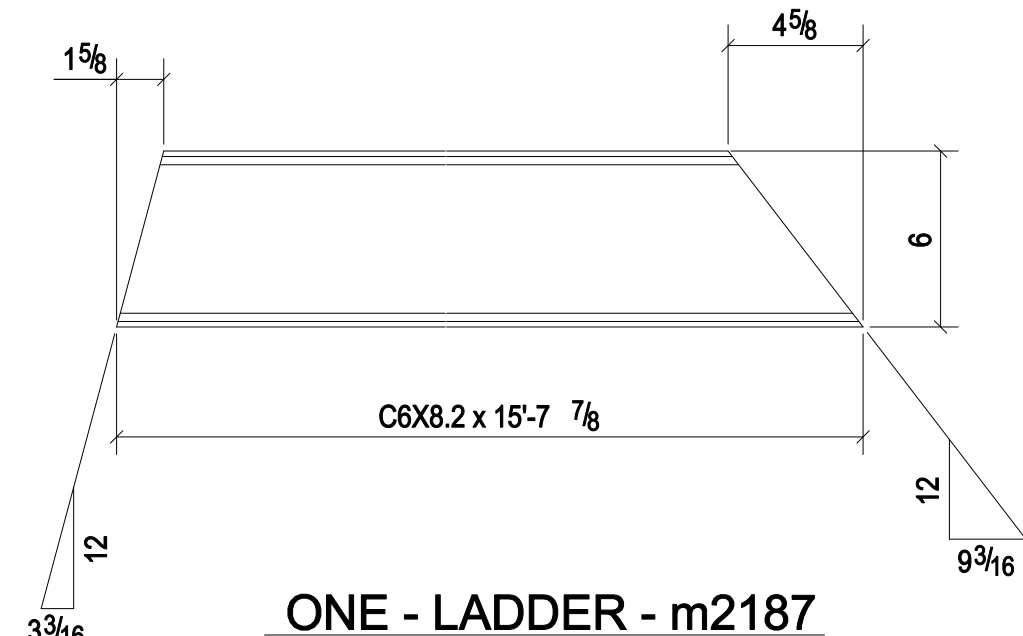

ONE - LADDER - m2187
(GR.-A36)

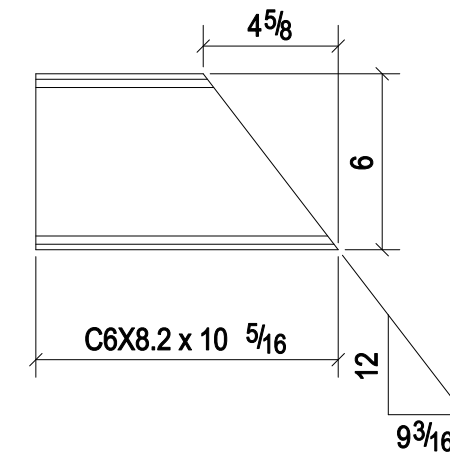

ONE - MISC - m2188
(GR.-A36)

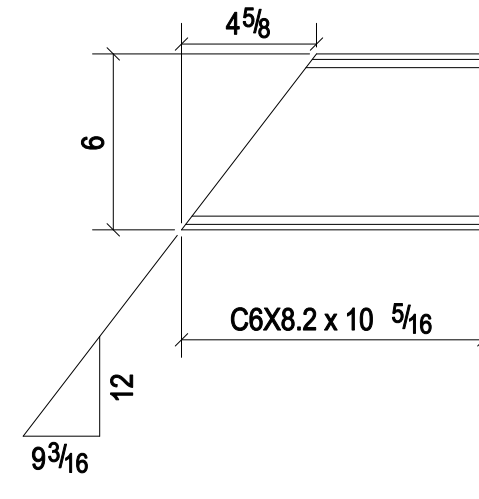

ONE - MISC - m2189
(GR.-A36)

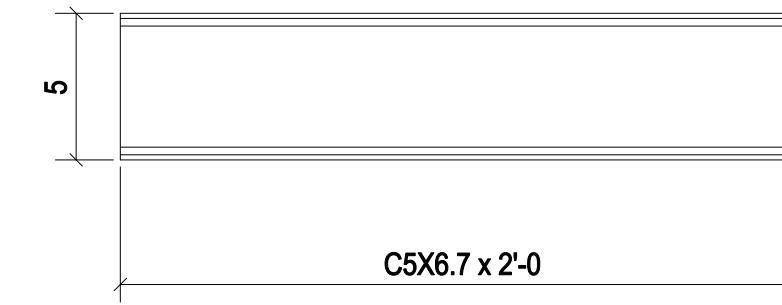

14 - MISCS - m2264
(GR.-A36)

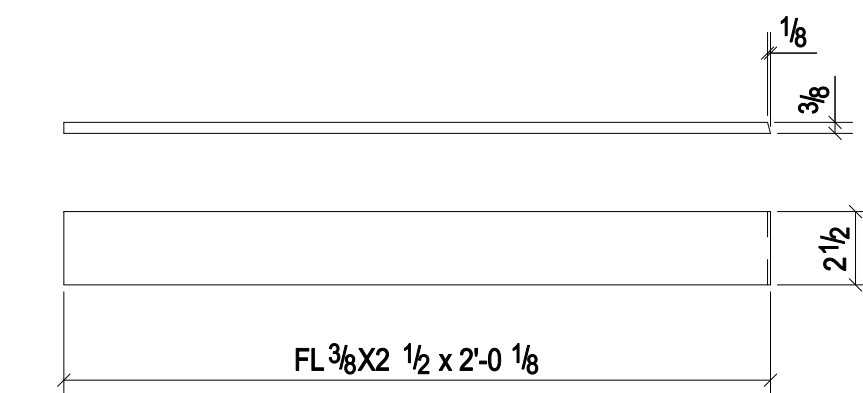

2 - PLATES - p1529
(GR.-A36)

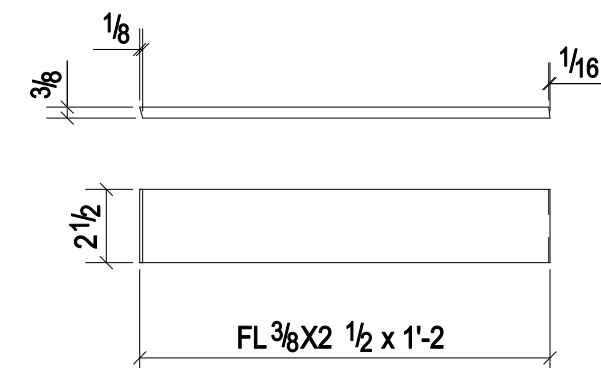

2 - PLATES - p1530
(GR.-A36)

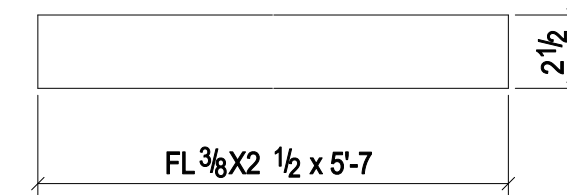

ONE - PLATE - p1531
(GR.-A36)

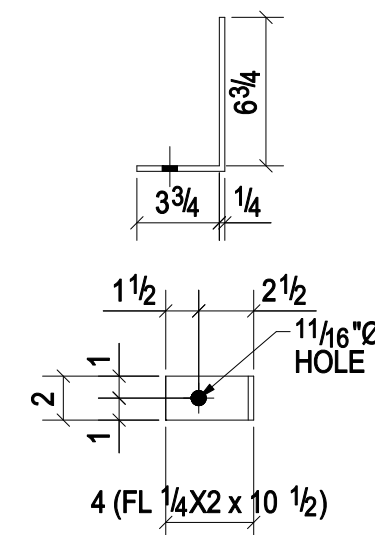

4 - BENT PLATES - p1542
(GR.-A36)

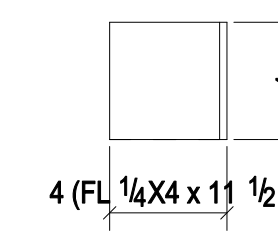
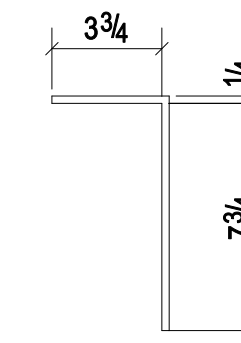

2 - PLATES - p1545
(GR.-A36)

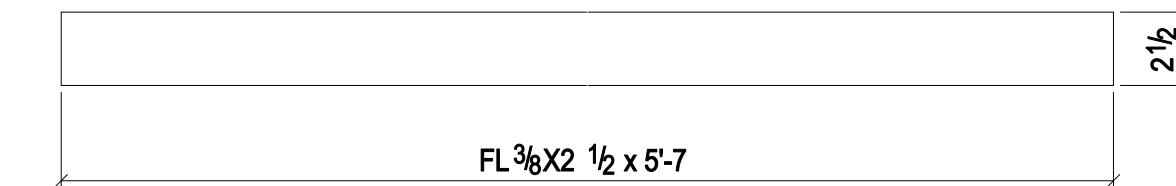

ONE - PLATE - p2086
(GR.-A36)

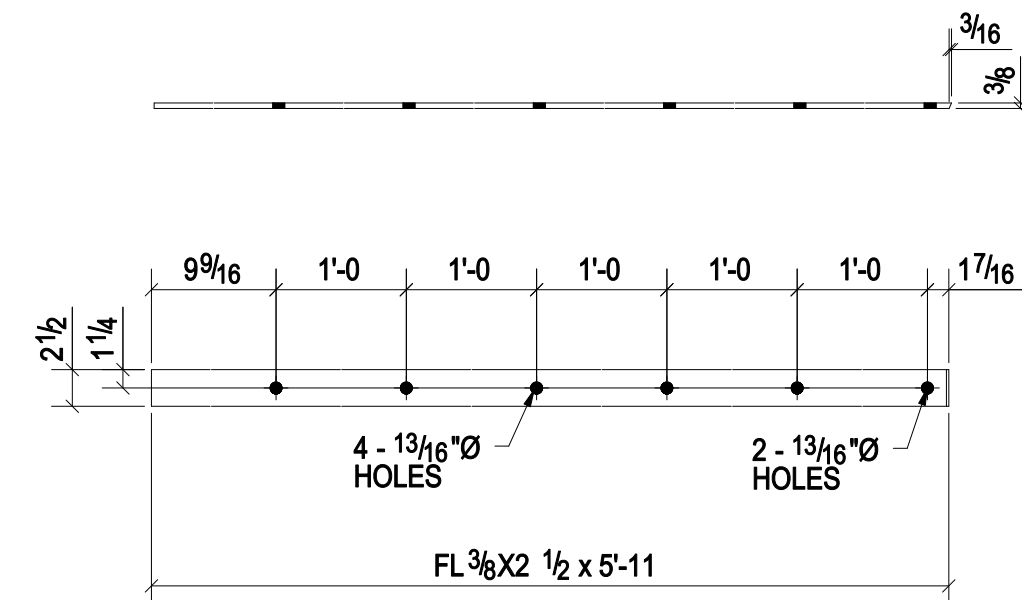

ONE - LADDER - p2458
(GR.-A36)

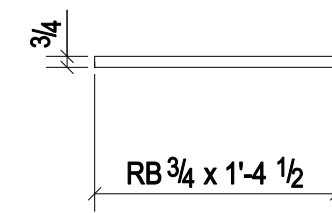

6 - RUNGS - r1
(GR.-A36)

SHOP DRAWING DISCLAIMER ALL INFORMATION PROVIDED ON THESE OR ANY OTHER DRAWINGS IS PREPARED IN ACCORDANCE WITH THE CONTRACT DOCUMENTS AND THE SPECIFICATIONS. ALL DIMENSIONS SHOWN ARE TO BE TAKEN FROM THE CONTRACT DOCUMENTS OR SPECIFICATIONS, BUT PREPARED WITH ALL THE INFORMATION AVAILABLE TO US. WE MUST HAVE YOUR APPROVAL BY THE ORIGINAL CONTRACTOR, ARCHITECT, & ENGINEER, BEFORE WE CAN START FABRICATING ANY MATERIAL. PLEASE RESPOND WITH THE INFORMATION BY MARKING UP OUR SHOP DRAWING.	CHANGES PER RF# REFERENCE CONTRACT SHEETS WELDS: E70XX HOLES: 13/16" HOLES UNO. STEEL: ASTM A992 UNO.	STANDARD SHOP NOTES 1. EA. END OF MATL. MAY DEVIATE FROM DIMS SHOWN BY 1/2" NORMAL AS MILL TOLERANCE FOR LENGTH AND SQUARENESS UNO. 2. WELDERS ARE TO USE PCAW AND/OR SMAW PROCESS PER AWS D1.1 UNLESS NOTED. 3. ALL MEMBERS TO BE FABRICATED WITH SHIPPING MARKS ON LEFT HAND END. 4. ALL SHOP BOLTS TO BE A325 UNO. 5. BURNING MARKS ARE GIVEN FROM END OF MAIN MATERIAL (A. BOTT. COIL & END OF BEAM). 6. 13/16" X 1" SLOTS @ 90° OF CLIP ANGLES UNO.	THIS DRAWING IS RELEASED FOR: FOR FABRICAT ITEM NO. 03	NO. _____ REVISION DESCRIPTION _____ DATE: 08/28/14	FOR FABRICATION GATHER SHEET	ITEM NO. 03 MG 08/28/14 1673	03G1 AS
	SHOP DRAWING DISAPPROVED DATE: _____						